



Naval & Mechanical Design



FIBERGLASS STRUCTURES

- Drawings and sizing calculations of composite structures.
- Lamination table calculations
- 3D structures model for Cutting Machine

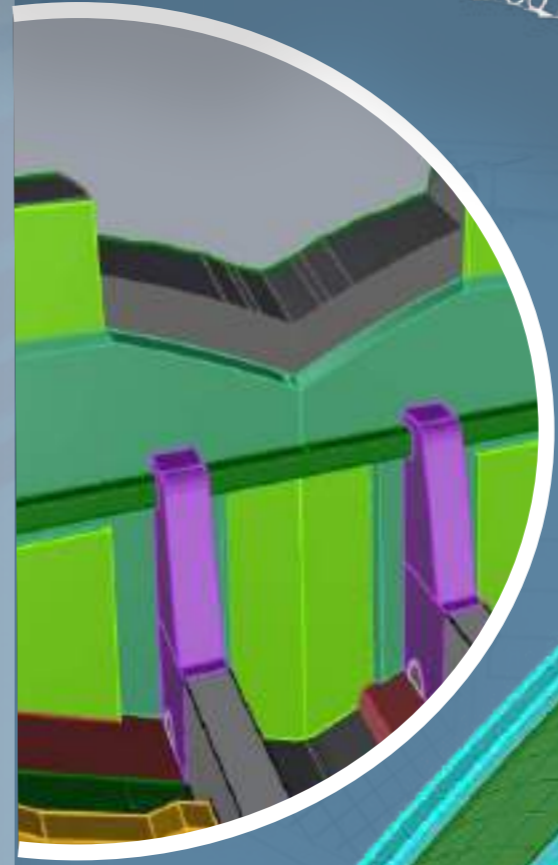
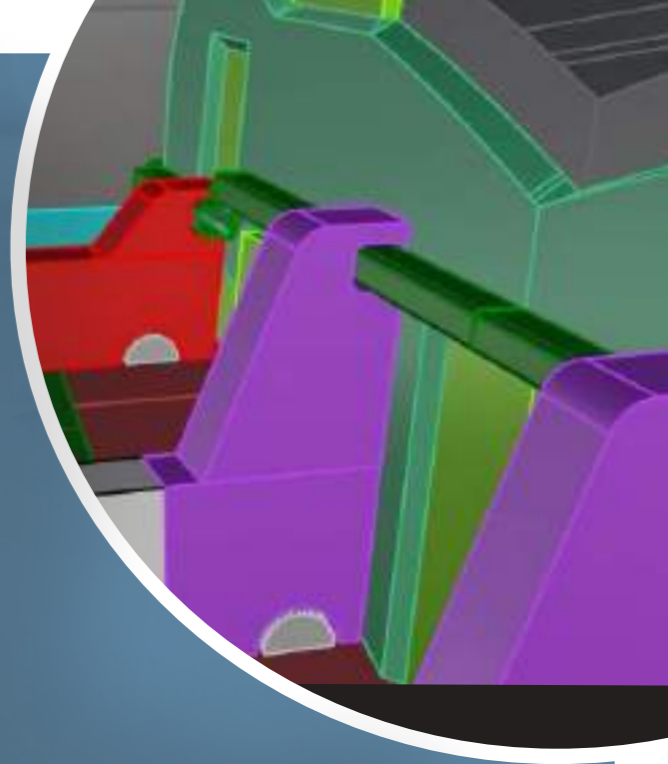
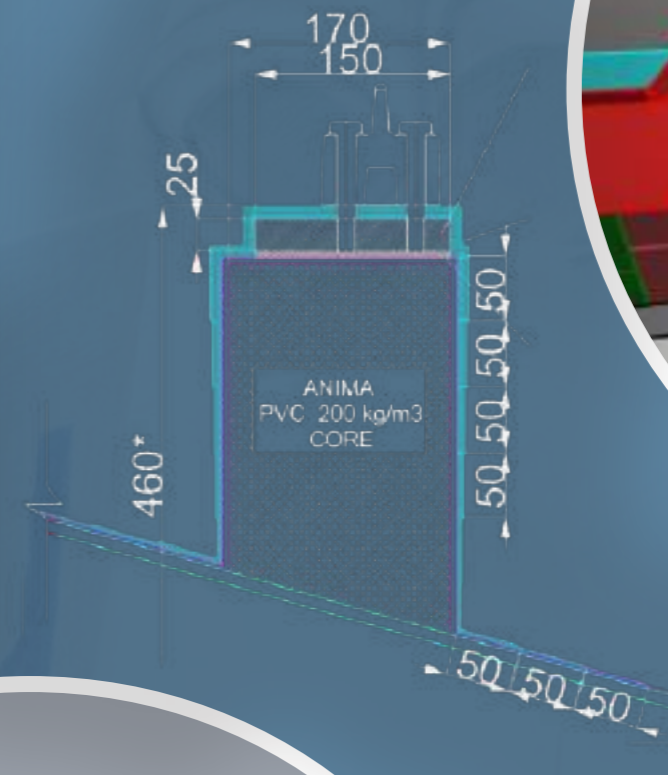
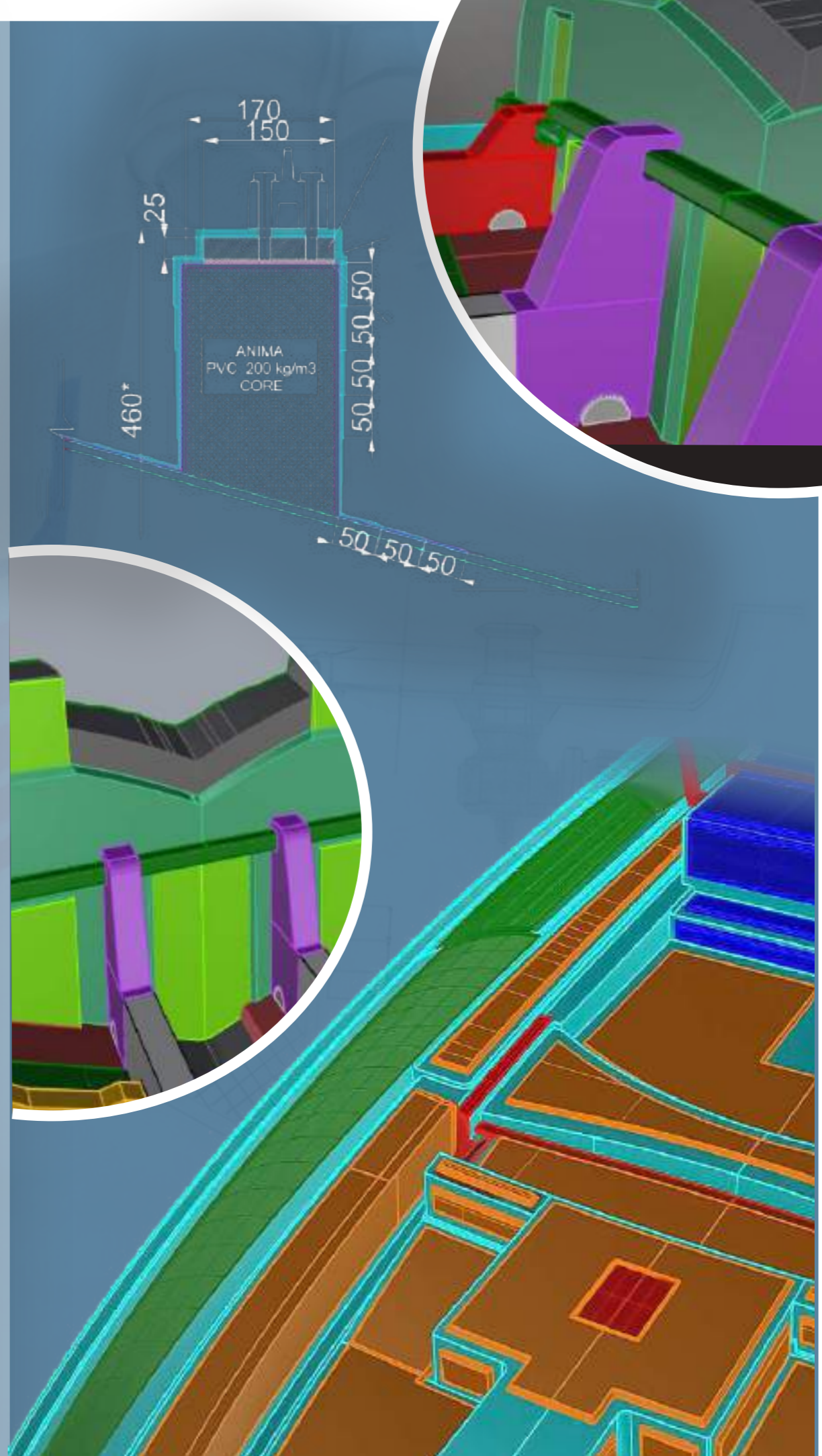
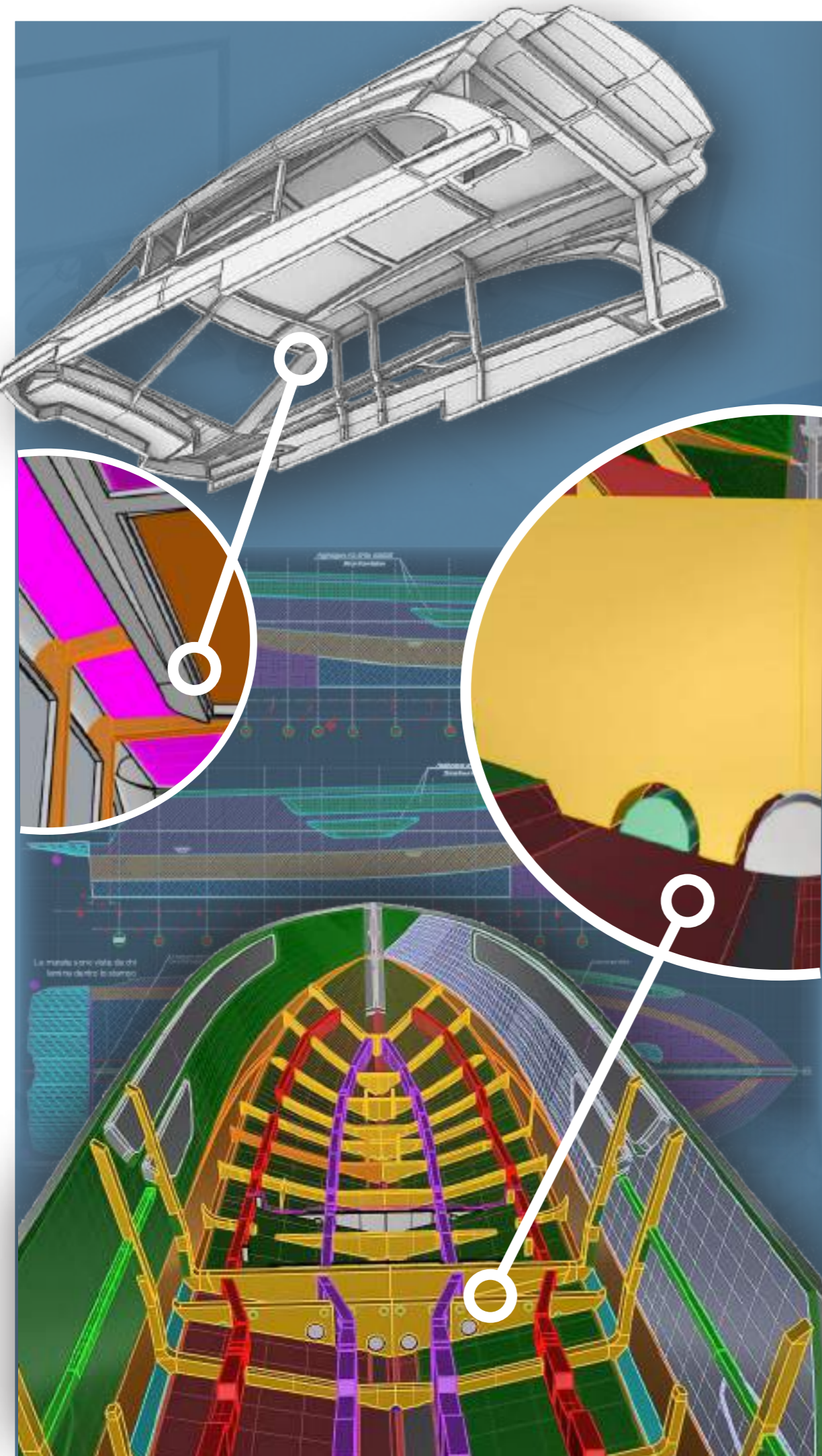



STEEL AND ALLUMINIUM STRUCTURES

- Drawings and sizing calculations of metal structures
- Classification plans, Construction and Nesting Drawings
- 3D structures model



ENGINE AND MACHINERY ARRANGEMENT

- Machinery layout, optimisation of the engine room (ER) and technical spaces.
- Shaft Line Propulsion Sizing

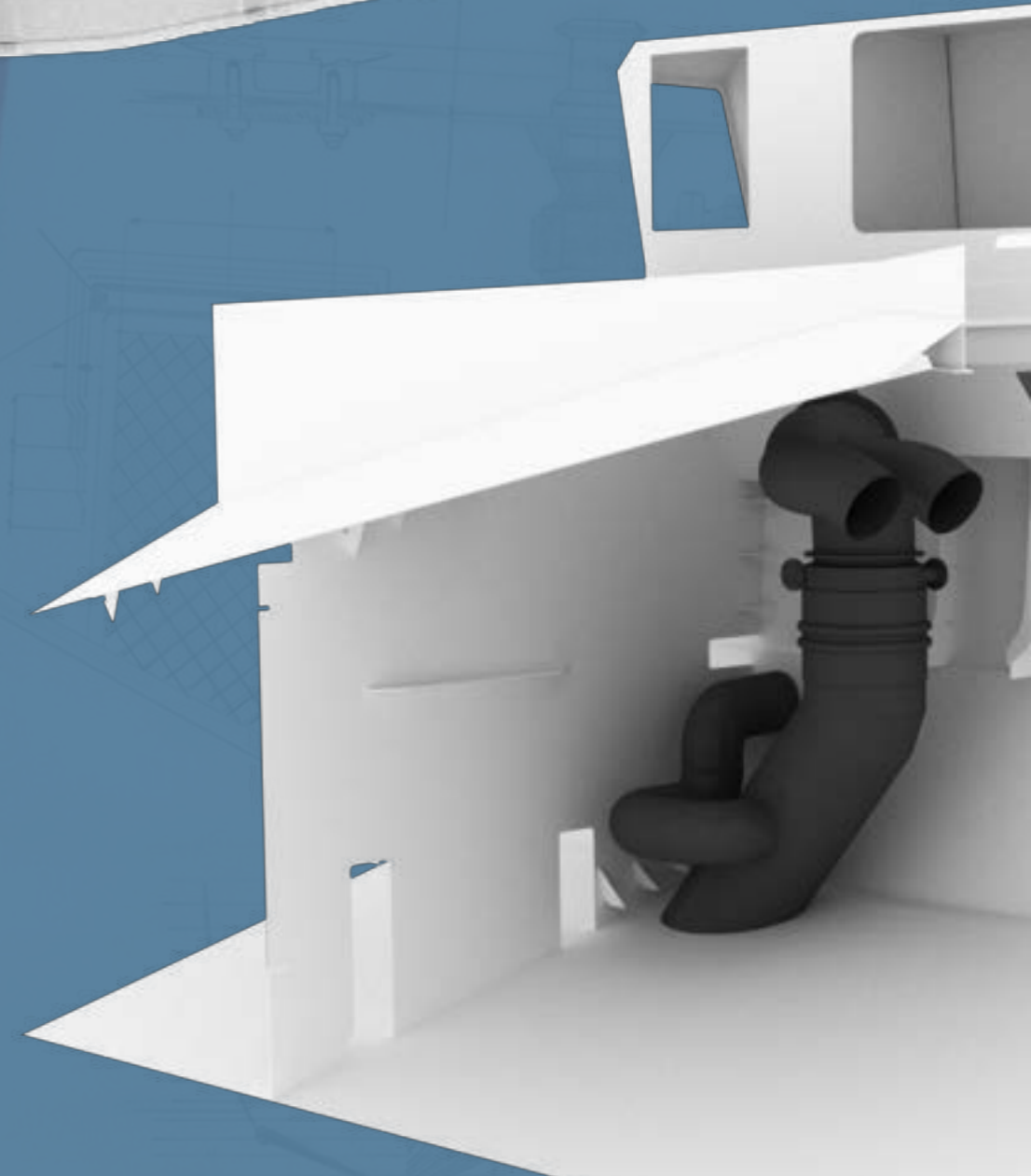
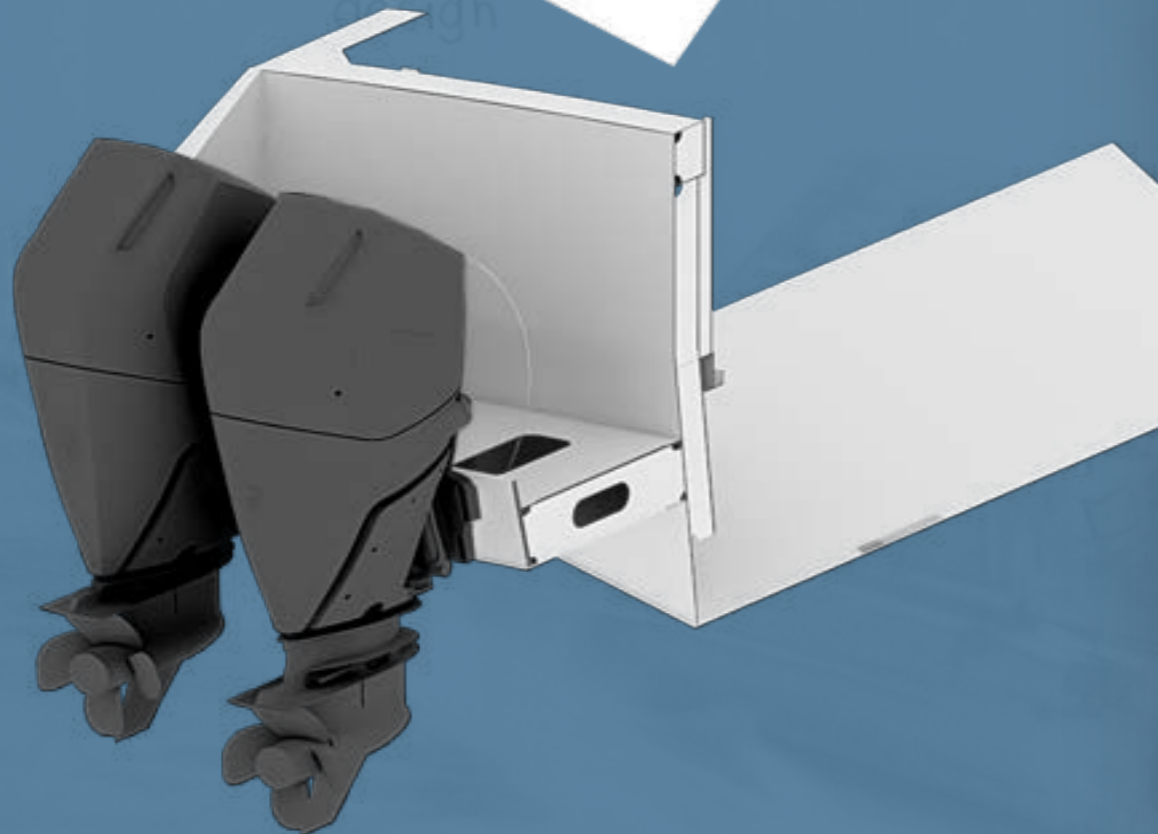
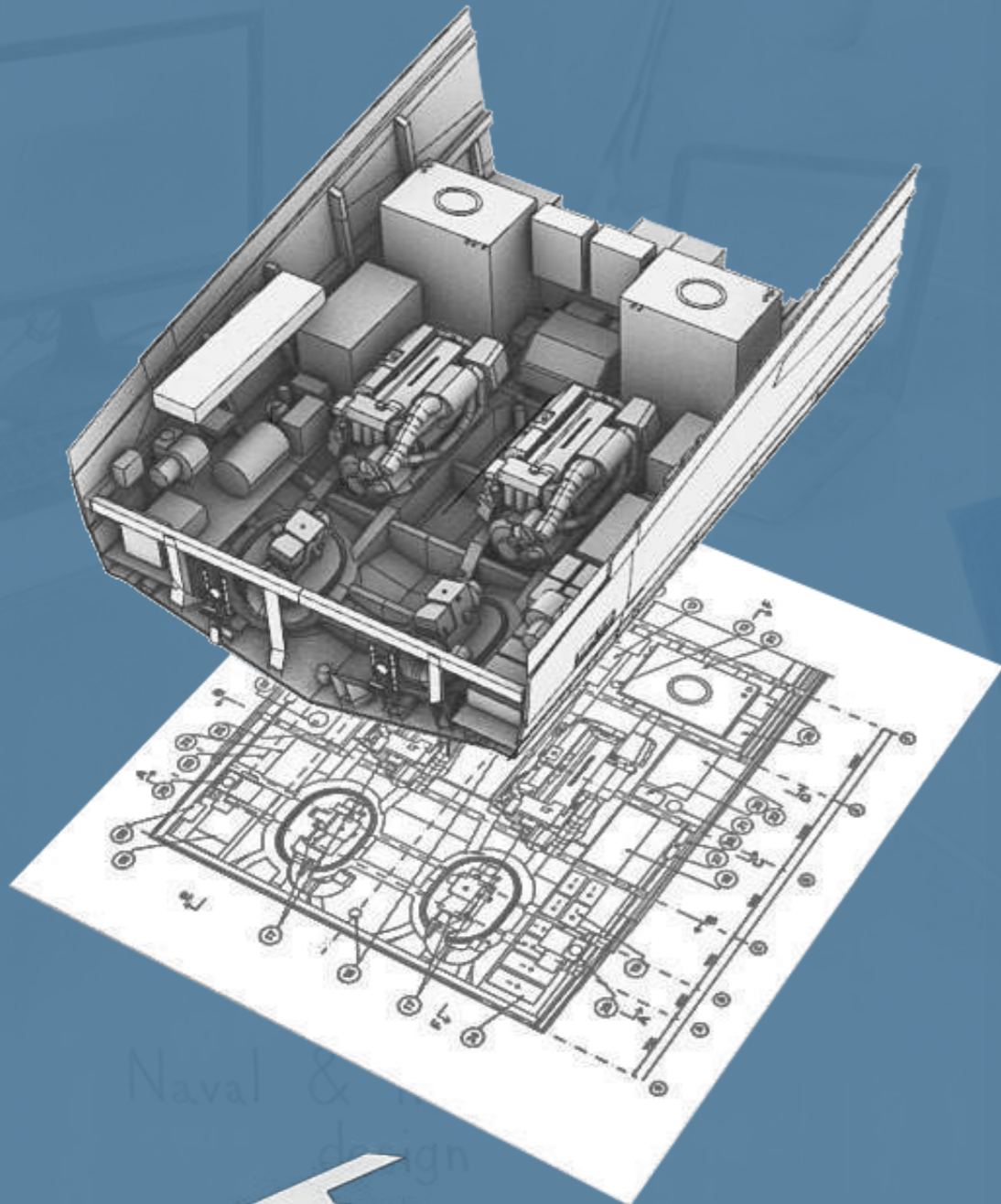

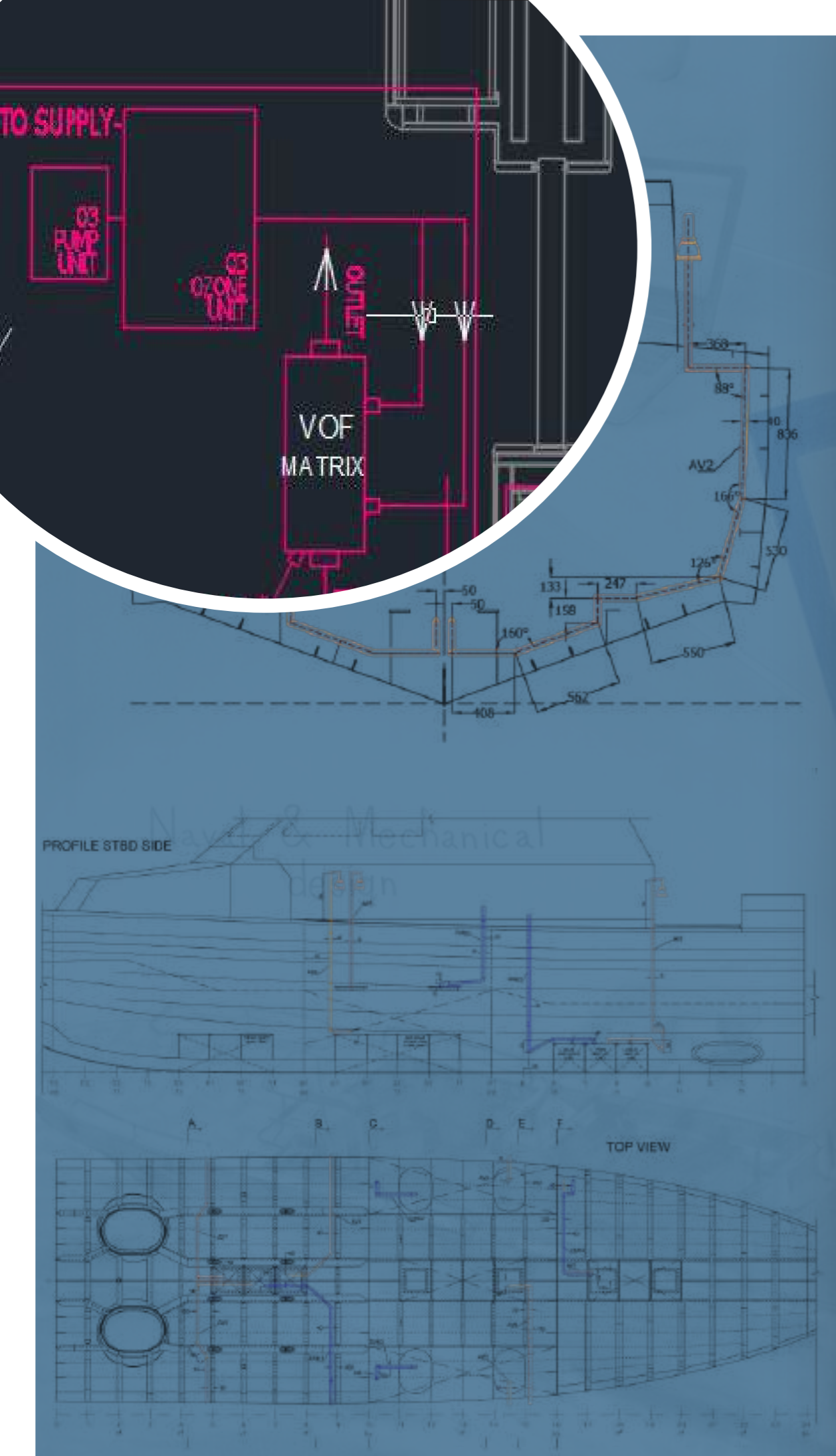

PIPING AND SYSTEMS

- 2D Systems
- 3D Piping and Valve List

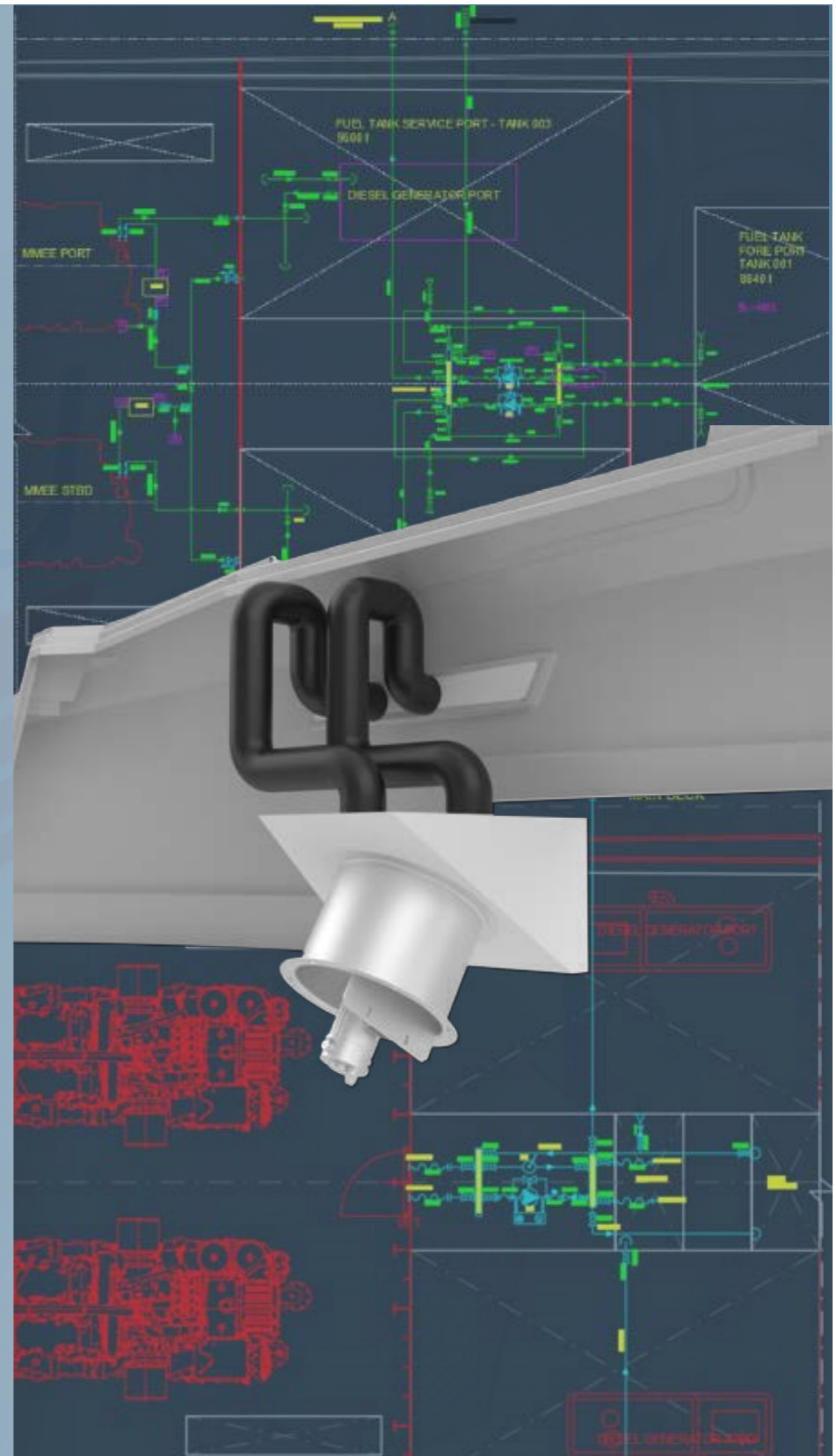



NAVAL ARCHITECTURE

- **General plans**
- **Speed prediction and Range calculation**
- **CE or Class Certification** with various **Naval Registers**
- **Exterior and interior design drawings**
- **Stability calculation & weight estimation**

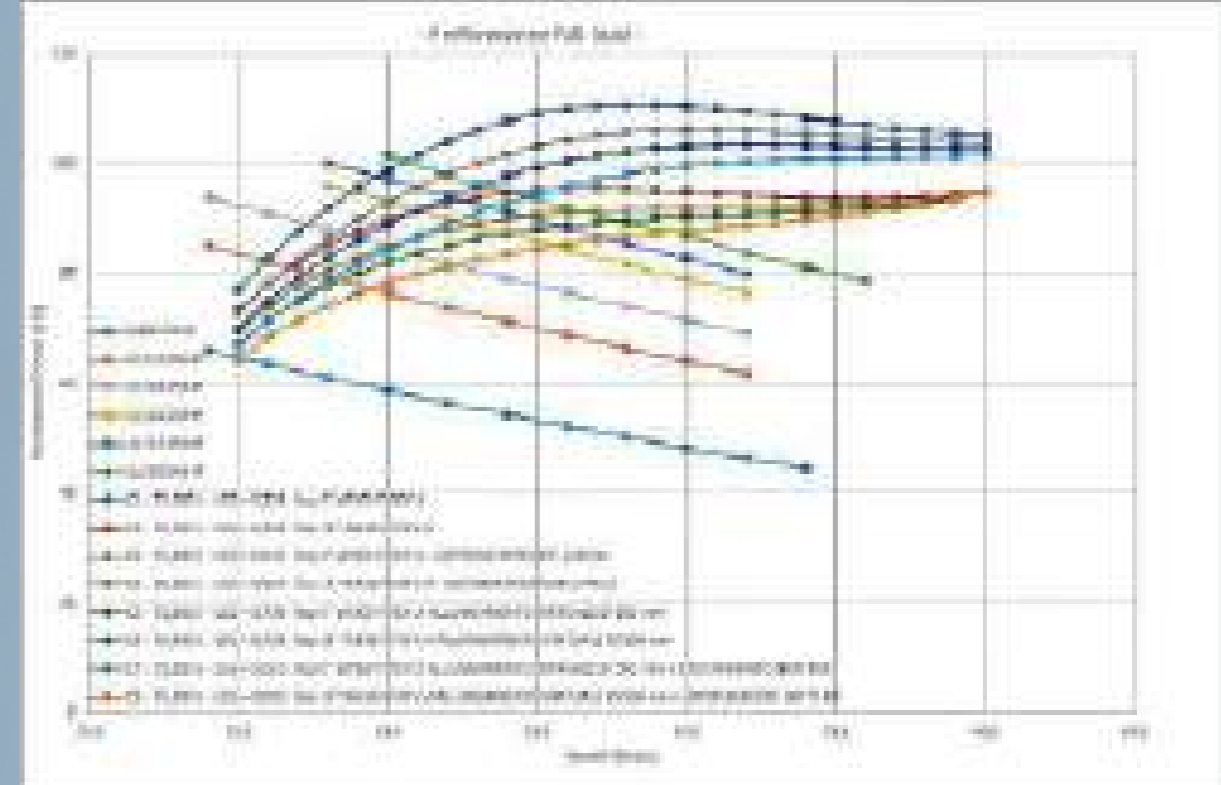
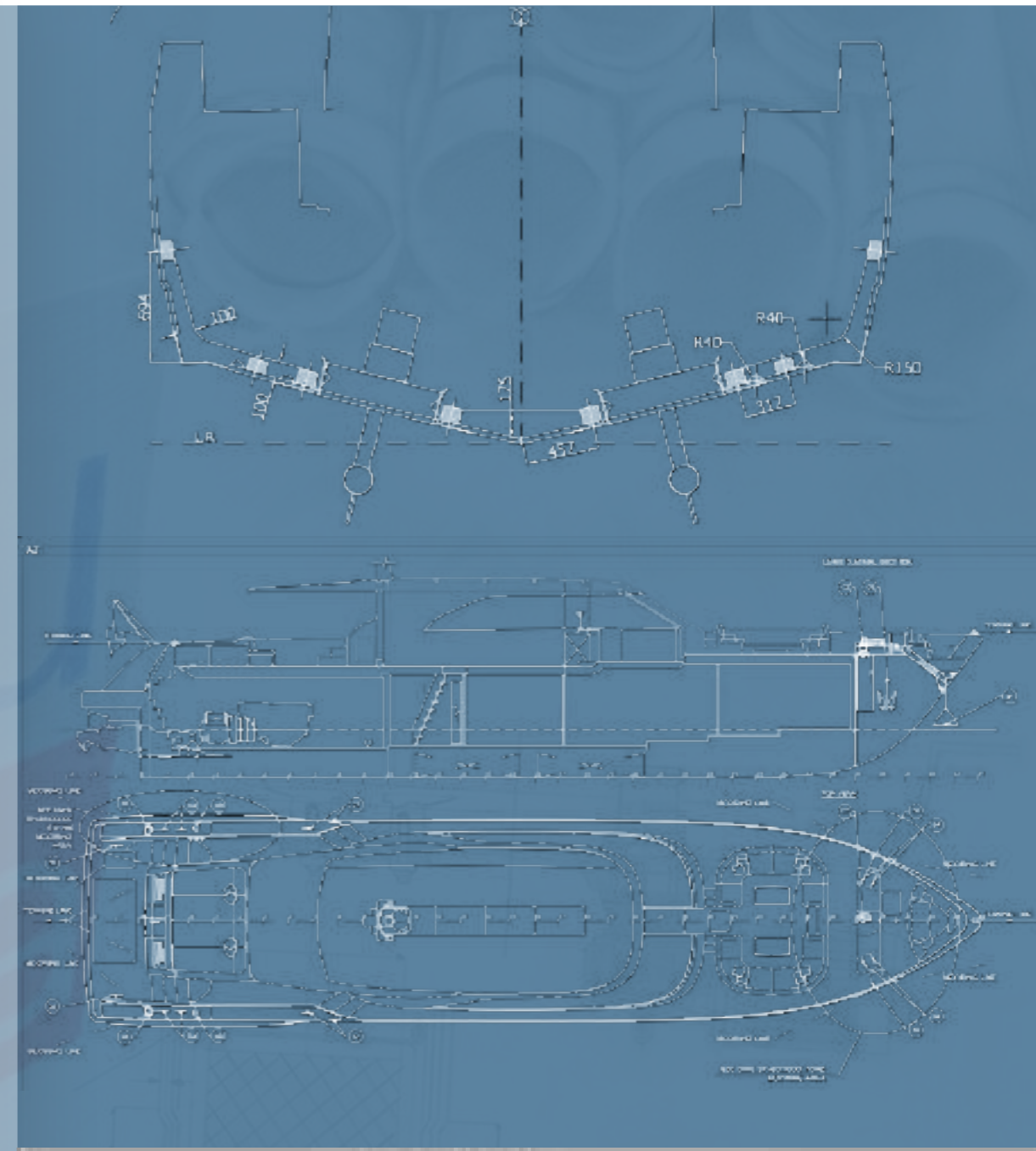
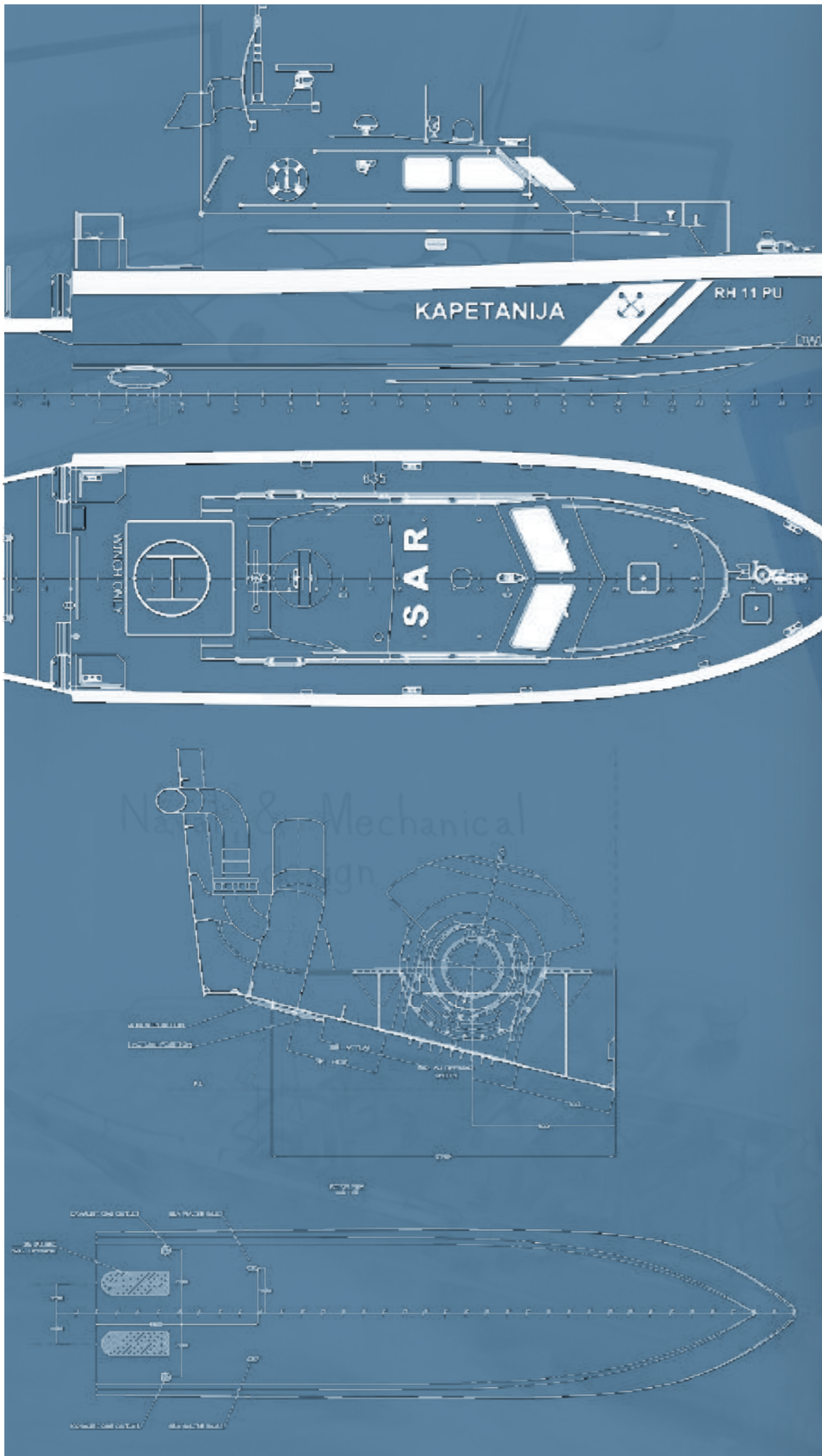

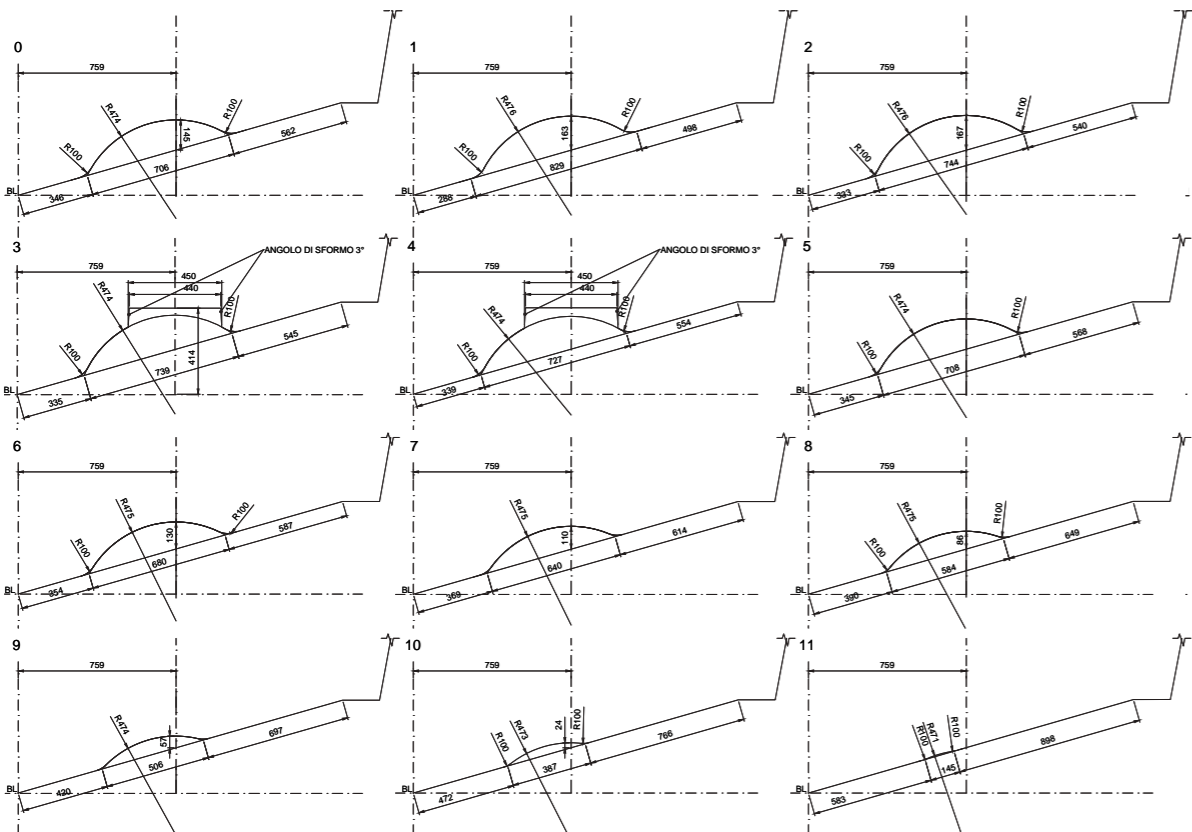
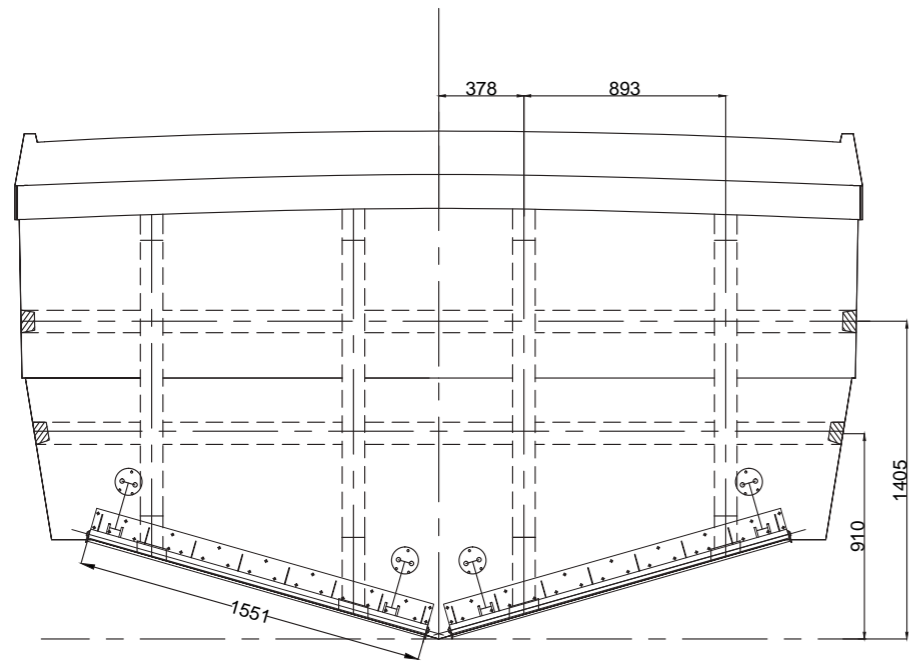
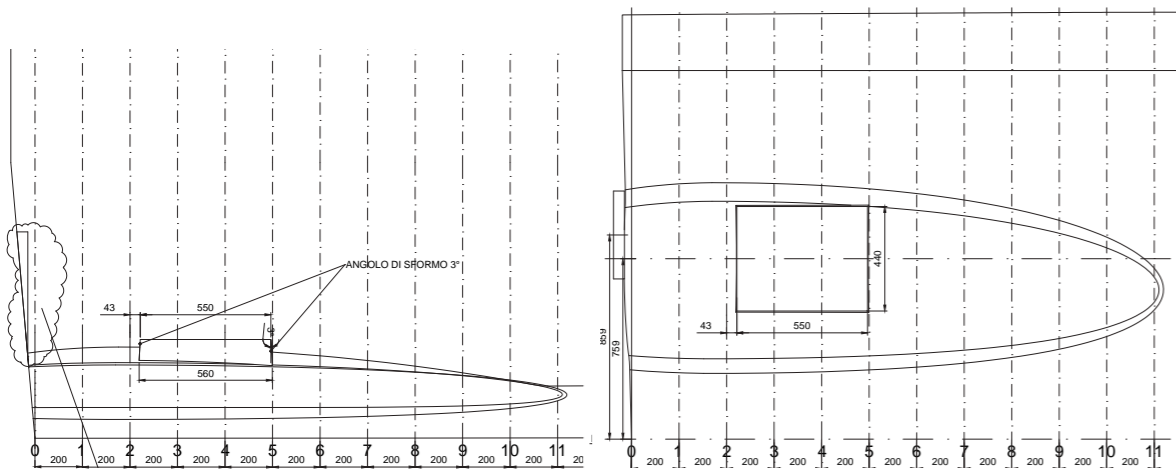

REFITTING

13 m RAFF
Italian Ministry of
the Interior -
V.V. F.

- Main Engines and propulsion system modification
- Performance prediction
- Stability calculation

Final Results:
Increased speed and
improved navigability

6

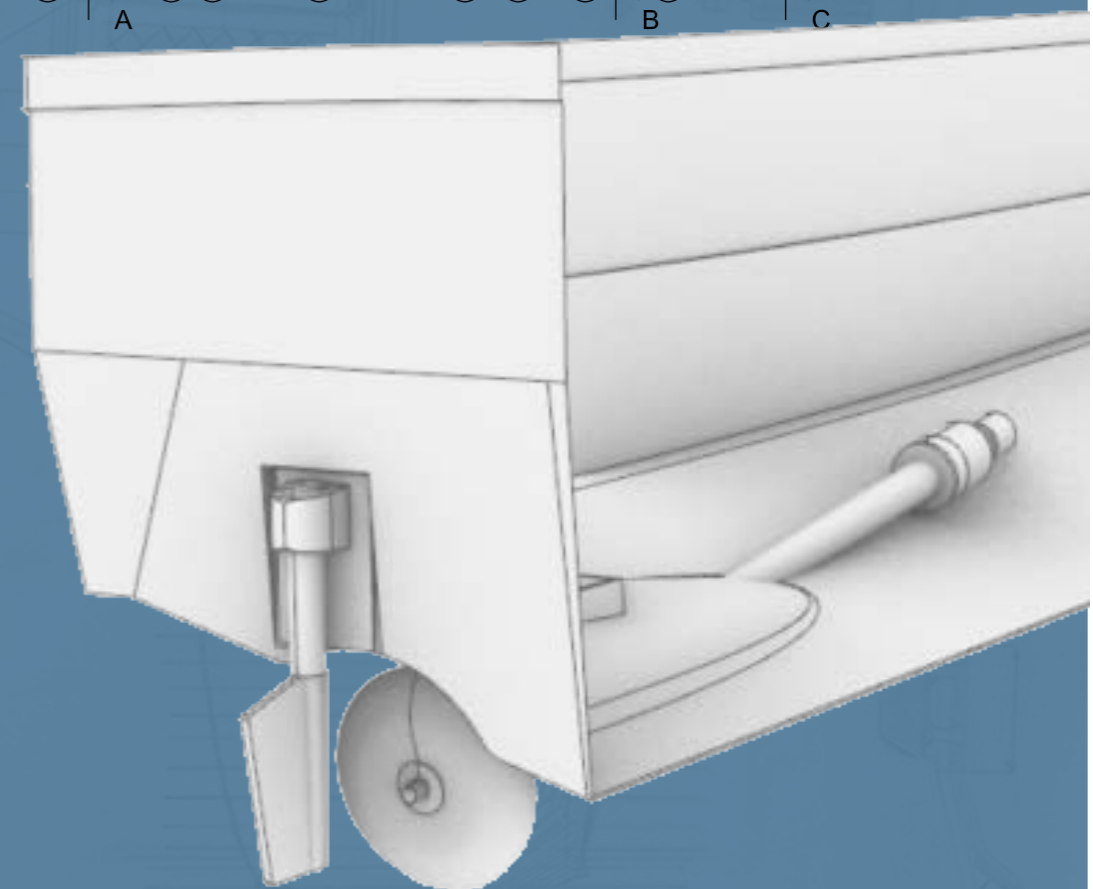
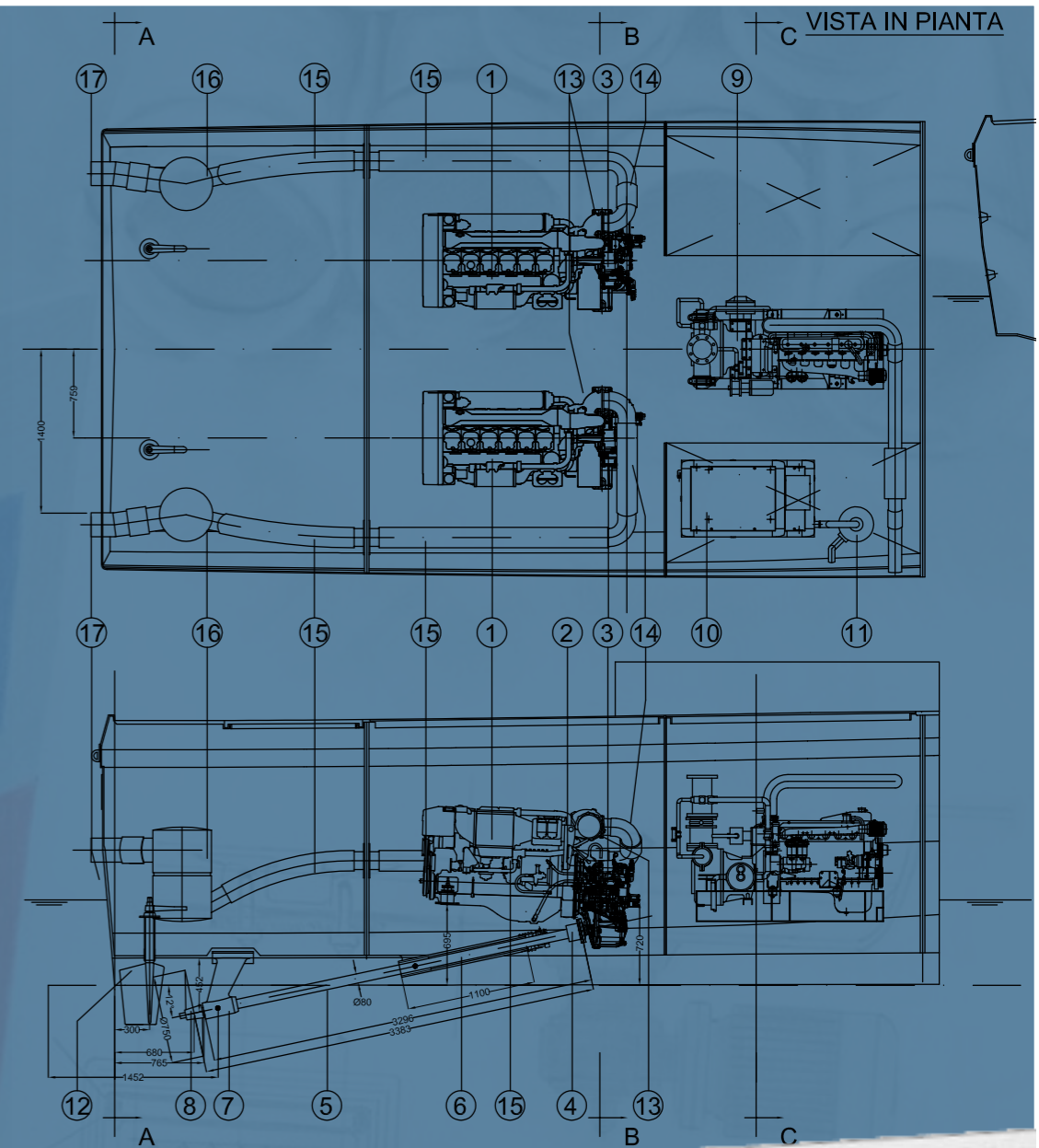



PLEASURE YACHTS

- 42' Sport fisher boat
- Capri 50' Sport fisher boat
- Maori 54'
- Cayman WA400
- Cayman WA540
- Cayman S600
- Cayman F580
- Capri 50' Sport fishing boat
- M/Y 25 m Eco Tender

and more...

7





MILITARY YACHTS

- Patrol Vessels
- Interceptors
- Landing Crafts
- SAR Search & Rescue

and more...





Contact us:



+39 3498179230

+39 3345832329



info@blusea.eu



<http://blusea.eu/>